

PAIR (2 SETS) ARTICULATED PIER POINT-TO-POINT SET

U5522

COMPATIBILITY



WEIGHT CAPACITY

33 lbs.
15 Kg

FINISH

Brushed nickel

INCLUDES

Upper and Lower Piers,
10 ft. cable, mounting
hardware, other fittings.

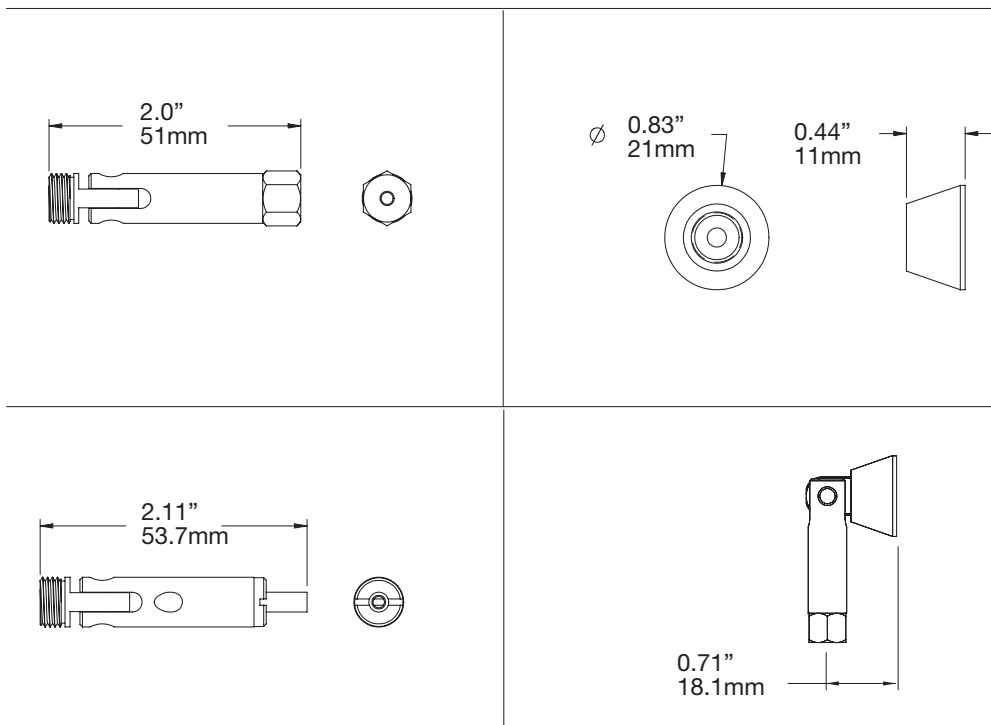

NOTE

The weight capacity of an individual pier/steel cable may be as low as 10 lbs. or less, or as high as 100 lbs. (static load), depending on the mounting hardware and installation technique. Actual capacity is dependent upon the installation.

ASHanging.com
866.935.6949