

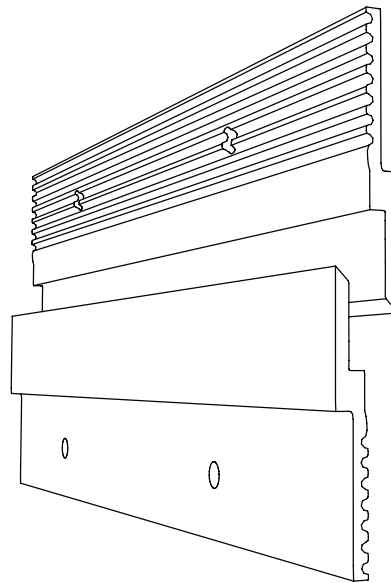

**FRENCH CLEAT HANGING BRACKET**

U5175

U5177



**FINISH**

Mill Finish (raw aluminum)

**NOTE**

U5175: 1.5-in wide  
U5177: 16-in wide

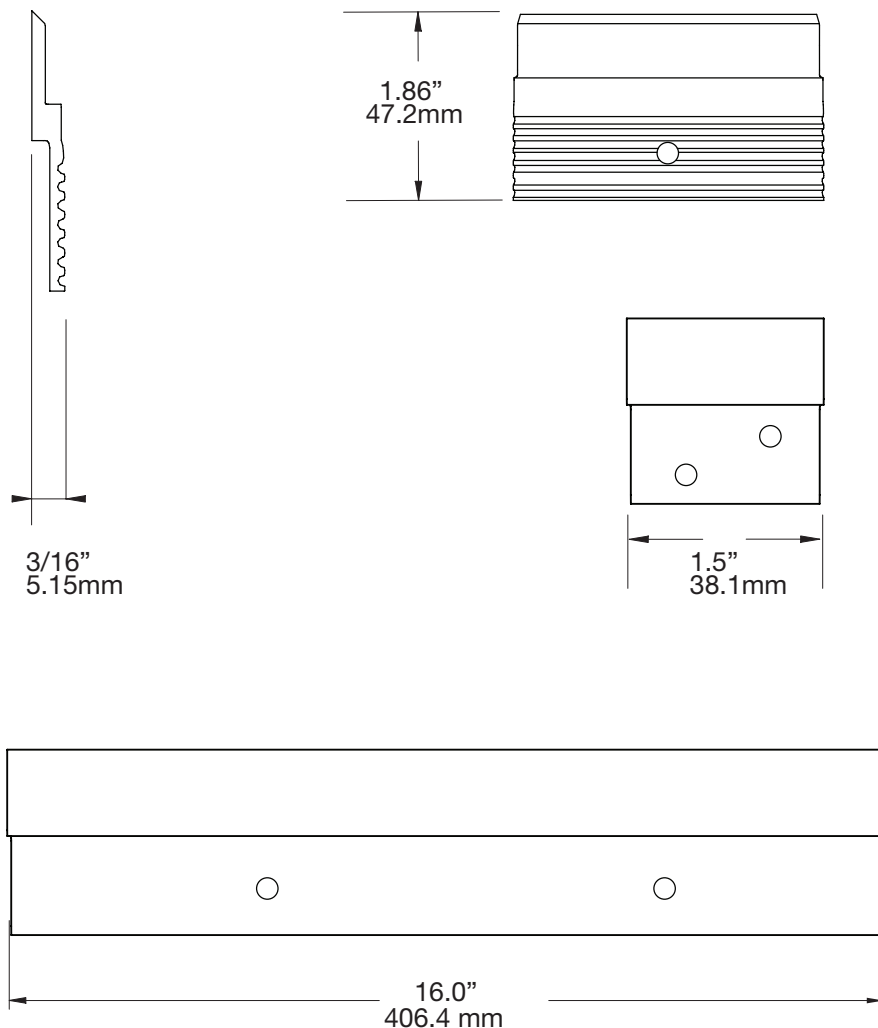

ASHanging.com  
866.935.6949