



**ANTI-THEFT  
SECURE ROD  
S1010**

**WEIGHT CAPACITY**  
70 lbs.  
32 Kg

**FINISH**  
Anodized: Silver Satin,  
Champagne, Gold

**LENGTH**  
24", 48", 60", 72", 96"

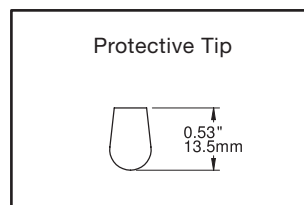
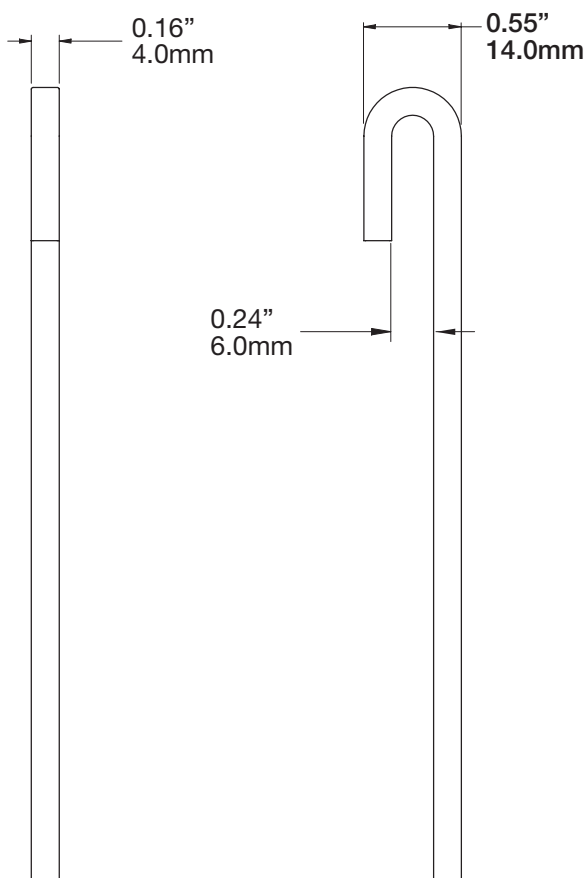

**ASHanging.com**  
866.935.6949