

**ECONO SIDE CLAMP,  
DOUBLE SIDED  
H3042**

**WEIGHT CAPACITY**  
2.5 lbs.  
1.1 Kg

**FINISH**  
Anodized aluminium

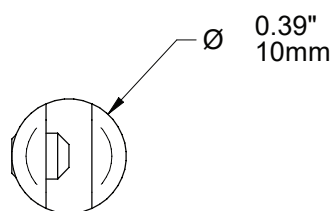
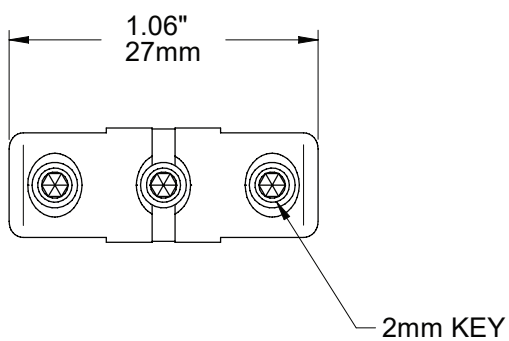
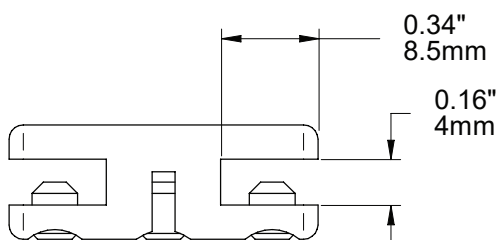

**ASHanging.com**  
866.935.6949